

3.3 VOLT ZERO DELAY, LOW SKEW BUFFER

MK2308-1

Description

The MK2308-1 is a low phase noise, high-speed PLL based, 8-output, low-skew zero delay buffer. Based on IDT's proprietary low jitter Phase Locked Loop (PLL) techniques, the device provides eight low skew outputs at speeds up to 133 MHz at 3.3 V. The outputs can be generated from the PLL (for zero delay), or directly from the input (for testing), and can be set to tri-state mode or to stop at a low level. For normal operation as a zero delay buffer, any output clock is tied to the FBIN pin.

Features

- Clock outputs from 10 to 133 MHz
- Zero input-output delay
- Eight low skew (<200 ps) outputs
- Device-to-device skew <700 ps
- Full CMOS outputs with 25 mA output drive capability at TTL levels
- 5 V tolerant FBIN and CLKIN pins
- Tri-state mode for board-level testing
- Advanced, low power, sub-micron CMOS process
- Operating voltage of 3.3 V
- Industrial temperature range available
- Available in Pb (lead) free package
- Packaged in 16-pin SOIC

Block Diagram

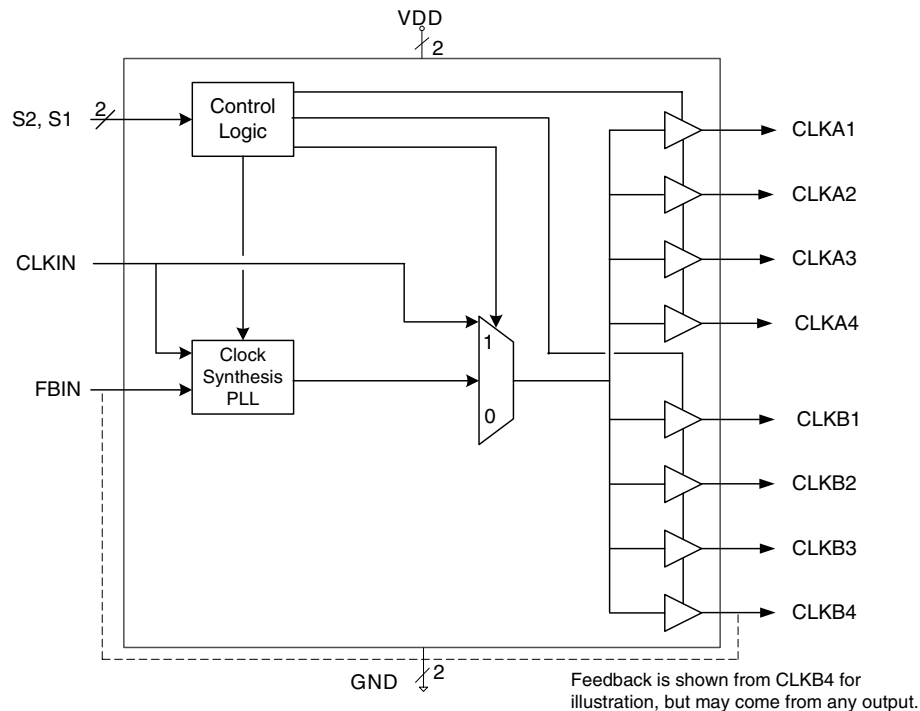

Pin Assignment

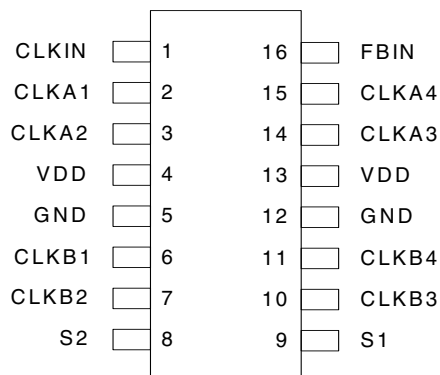

16 pin narrow (150 mil) SOIC

Output Clock Mode Select Table

S2	S1	CLKA1:A4	CLKB1:B4	A & B Source	PLL Status
0	0	Tri-state (note 1)	Tri-state (note 1)	PLL	OFF
0	1	Running	Tri-state (note 1)	PLL	ON
1	0	Running	Running	CLKIN (note 2)	OFF
1	1	Running	Running	PLL	ON

Note 1. Outputs are in high impedance state

Note 2. Buffer mode only; not zero delay between input and output

Pin Descriptions

Pin Number	Pin Name	Pin Type	Pin Description
1	CLKIN	Input	Clock input (5 V tolerant).
2 - 3	CLKA1:A4	Output	Clock outputs A1:A4. See table above.
4	VDD	Power	Power supply. Connect to 3.3 V.
5	GND	Power	Connect to ground.
6 - 7	CLKB1:B4	Output	Clock outputs B1:B4. See table above.
8	S2	Input	Select input 2. See table above. Internal pull-up.
9	S1	Input	Select input 1. See table above. Internal pull-up.
10 - 11	CLKB1:B4	Output	Clock outputs B1:B4. See table above.
12	GND	Power	Connect to ground.
13	VDD	Power	Power supply. Connect to 3.3 V.
14 - 15	CLKA1:A4	Output	Clock outputs A1:A4. See table above.
16	FBIN	Input	Feedback input. Connect to any output under normal operation (5 V tolerant).

External Components

The MK2308-1 requires a minimum number of external components for proper operation. Decoupling capacitors of 0.01 μ F should be connected between VDD and GND on pins 4 and 5, and VDD and GND on pins 13 and 12, as close to the device as possible. A series termination resistor of 33 Ω may be used to each clock output pin to reduce reflections.

Absolute Maximum Ratings

Stresses above the ratings listed below can cause permanent damage to the MK2308-1. These ratings, which are standard values for IDT commercially rated parts, are stress ratings only. Functional operation of the device at these or any other conditions above those indicated in the operational sections of the specifications is not implied. Exposure to absolute maximum rating conditions for extended periods can affect product reliability. Electrical parameters are guaranteed only over the recommended operating temperature range.

Item	Rating
Supply Voltage, VDD	7 V
All Inputs and Outputs	-0.5 V to VDD+0.5 V
CLKIN and FBIN inputs	-0.5 V to 5.5 V
Electrostatic Discharge	2000 V
Ambient Operating Temperature	0 to +70°C
Industrial Temperature	-40 to +85°C
Commercial temperature	0 to 70°C
Storage Temperature	-65 to +150°C
Junction Temperature	150°C
Soldering Temperature	260°C

Recommended Operation Conditions

Parameter	Min.	Typ.	Max.	Units
Ambient Operating Temperature (Industrial)	-40		+85	°C
Ambient Operating Temperature (Commercial)	0		+70	°C
Power Supply Voltage (measured in respect to GND)	+3.0		+3.6	V

DC Electrical Characteristics

VDD=3.3 V ±10%, Ambient temperature -40 to +85°C(Industrial), (0-70°C Commercial),

Parameter	Symbol	Conditions	Min.	Typ.	Max.	Units
Operating Voltage	VDD		3.0		3.6	V
Input High Voltage	V _{IH}		2			V
Input Low Voltage	V _{IL}				0.8	V
Input Low Current	I _{IL}	VIN = 0V			50	μA
Input High Current	I _{IH}	VIN = VDD			100	μA
Output High Voltage	V _{OH}	I _{OH} = -12 mA	2.4			V
Output Low Voltage	V _{OL}	I _{OL} = 12 mA			0.4	V
Output High Voltage, CMOS level	V _{OH}	I _{OH} = -4 mA	VDD-0.4			V
Operating Supply Current	IDD	No Load, S2 = 1, S1 = 1, Note 1			70	mA
Power Down Supply Current	IDDPD	CLKIN = 0, S2 = 0, S1 = 1		12		μA
		CLKIN = 0, Note 2		12		μA
Short Circuit Current	I _{OS}	Each output		±50		mA
Input Capacitance	C _{IN}	S2, S1, FBIN		5		pF

AC Electrical Characteristics

VDD = 3.3 V ±10%, Ambient Temperature -40 to +85°C(Industrial), (0-70°C Commercial)

Parameter	Symbol	Conditions	Min.	Typ.	Max.	Units
Input Clock Frequency	f _{IN}	See table on page 2	10		133	MHz
Output Clock Frequency		See table on page 2	10		133	MHz
Output Rise Time	t _{OR}	0.8 to 2.0 V, CL=30 pF			1.5	ns
Output Fall Time	t _{OF}	2.0 to 0.8 V, CL=30 pF			1.25	ns
Output Clock Duty Cycle	t _{DC}	measured at VDD/2	45	50	55	%
Device to Device Skew		rising edges at VDD/2			700	ps
Output to Output Skew		rising edges at VDD/2			200	ps
Input to Output Skew		Delay CLKIN Rising Edge to FBIN Rising Edge			±250	ps
Maximum Absolute Jitter		CL=15 pF, measured at 66.67M		130		ps
Cycle to Cycle Jitter		CL=30 pF, measured at 66.67M			200	ps
		CL=15 pF, measured at 66.67M			200	ps
		CL=15 pF, measured at 133.33M			100	ps
PLL Lock Time		Note 3			1.0	ms

Note 1: With CLKIN = 100MHz, FBIN to CLKA4, all outputs at 100 MHz

Note 2: When there is no clock signal present at CLKIN, the MK2308-1 will enter power down mode. The PLL is stopped and the outputs are tri-state.

Note 3: With VDD at a steady rate and valid clocks at CLKIN and FBIN

Thermal Characteristics

Parameter	Symbol	Conditions	Min.	Typ.	Max.	Units
Thermal Resistance Junction to Ambient	θ_{JA}	Still air		120		°C/W
	θ_{JA}	1 m/s air flow		115		°C/W
	θ_{JA}	3 m/s air flow		105		°C/W
Thermal Resistance Junction to Case	θ_{JC}			58		°C/W

3.3 VOLT ZERO DELAY, LOW SKEW BUFFER
MK2308-1
Package Outline and Package Dimensions (16-pin SOIC, 150 Mil. Narrow Body)

Package dimensions are kept current with JEDEC Publication No. 95

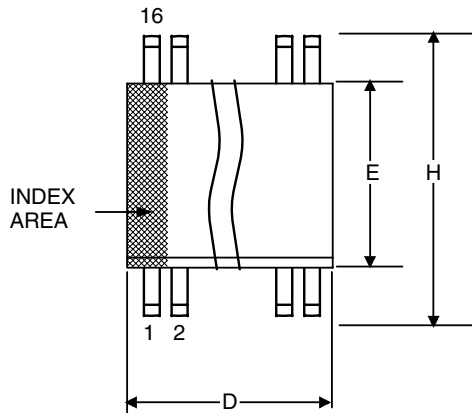

Symbol	Millimeters		Inches	
	Min	Max	Min	Max
A	1.35	1.75	.0532	.0688
A1	0.10	0.25	.0040	.0098
B	0.33	0.51	.013	.020
C	0.19	0.25	.0075	.0098
D	9.80	10.00	.3859	.3937
E	3.80	4.00	.1497	.1574
e	1.27 BASIC		0.050 BASIC	
H	5.80	6.20	.2284	.2440
h	0.25	0.50	.010	.020
L	0.40	1.27	.016	.050
α	0°	8°	0°	8°

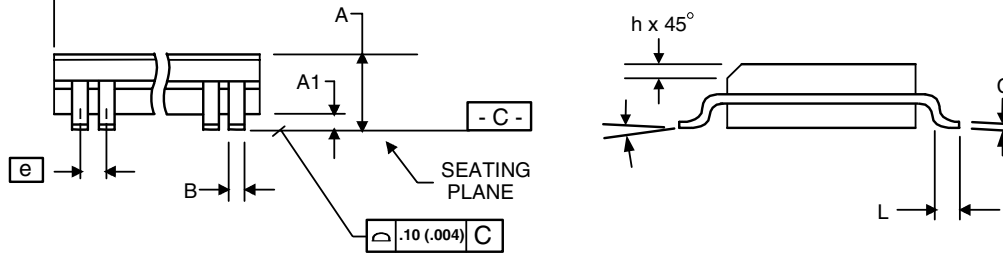
Ordering Information

Part / Order Number	Marking	Shipping Packaging	Package	Temperature
MK2308S-1I	MK2308S-1I	Tubes	16-pin SOIC	-40 to +85° C
MK2308S-1IT	MK2308S-1I	Tape and Reel	16-pin SOIC	-40 to +85° C
MK2308S-1	MK2308S-1	Tubes	16-pin SOIC	0 to +70° C
MK2308S-1T	MK2308S-1	Tape and Reel	16-pin SOIC	0 to +70° C
MK2308S-1ILF	MK2308S-1ILF	Tubes	16-pin SOIC	-40 to +85° C
MK2308S-1ILFT	MK2308S-1ILF	Tape and Reel	16-pin SOIC	-40 to +85° C
MK2308S-1LF	MK2308S-1LF	Tubes	16-pin SOIC	0 to +70° C
MK2308S-1LFT	MK2308S-1LF	Tape and Reel	16-pin SOIC	0 to +70° C

While the information presented herein has been checked for both accuracy and reliability, Integrated Device Technology (IDT) assumes no responsibility for either its use or for the infringement of any patents or other rights of third parties, which would result from its use. No other circuits, patents, or licenses are implied. This product is intended for use in normal commercial applications. Any other applications such as those requiring extended temperature range, high reliability, or other extraordinary environmental requirements are not recommended without additional processing by IDT. IDT reserves the right to change any circuitry or specifications without notice. IDT does not authorize or warrant any IDT product for use in life support devices or critical medical instruments.

Innovate with IDT and accelerate your future networks. Contact:

www.IDT.com

For Sales

800-345-7015
408-284-8200
Fax: 408-284-2775

For Tech Support

408-284-4522
clockhelp@idt.com

Corporate Headquarters

Integrated Device Technology, Inc.
www.idt.com



www.IDT.com